



# Galileo-E6 Bandwidth Frequency Filter Design for Galileo Receiver

*Surachet Chinnapark, Narumol Onanong, Julongkorn Pattameak, Teerachet Mekpradab, Prasert Kenpankho*

Department of Engineering Education, School of Industrial Education and Technology  
King Mongkut's Institute of Technology Ladkrabang, Thailand  
Correspondence: E-mail: [63603070@kmitl.ac.th](mailto:63603070@kmitl.ac.th)

## ABSTRACT

This research discusses about the combination of the LPF and HPF to perform band reject filter. Therefore, there are two combination also in designing band reject filter. The aim of this combination to get know is there have an influence on the performance of band reject filter was designed by using the frequency of the GalileoE6 with bandwidth 40 MHz. This filter is used a Butterworth filter which is presented in this study. These filter circuit is composed 4rd order. In addition to, the combination between LPF and HPF forming to a band reject filter is designed. As a result, the filter design on the frequency of Galileo-E6 is successfully used in band reject filter.

© 2021 Universitas Pendidikan Indonesia

## ARTICLE INFO

### **Article History:**

*Submitted/Received 10 Feb 2021*

*First revised 10 Mar 2021*

*Accepted 15 May 2021*

*First available online 17 May 2021*

*Publication date 01 Sep 2021*

### **Keyword:**

*ARNS,  
Filter Galileo-E6,  
Galileo receiver*

## 1. INTRODUCTION

Galileo is an autonomous navigation and positioning service under civilian control compatible and interoperable with GPS (Hegarty & Chatre, 2008; Hadas et al., 2019). The signal frequency on Galileo-E6 is the same frequency as on GPS and GLONASS (1278.75MHz) with bandwidth at 40MHz (Ortega et al., 2020). Band reject filter is designed for studying Galileo-E6 bandwidth frequency filter on Galileo-E6 receiver frequency between 1260MHz and 1300MHz with bandwidth 40 MHz which includes in the allocated spectrum for Aeronautical Radio Navigation Services (ARNS) (Aragon et al., 2021; Susi & Borio, 2020; Das et al., 2020). The carrier frequencies of Galileo-E6 at center frequency is 1278.75 MHz (Stansell, 2020). The Butterworth band reject filter is one type of signal processing filter design (Sagath et al., 2019). There is seldom studied about Galileo-E6 bandwidth filter design. In this study, we studied and designed the band reject pass filter on the frequency of the Galileo-E6 satellite by providing its bandwidth at the cut-off frequency. The selecting of response characteristic is Butterworth maximally flat, amplitude-frequency response of band reject filter.

## 2. METHODS

This study is presented about configuration of circuit on Butterworth band reject filter by using PSpice as the tools for the simulation that shows in **Figure 1**.

From the Galileo-E6 signal frequency

$$f_l = 1260 \text{ MHz} \quad (1)$$

$$f_h = 1300 \text{ MHz} \quad (2)$$

$$f_0 = 1278.75 \text{ MHz} \quad (3)$$

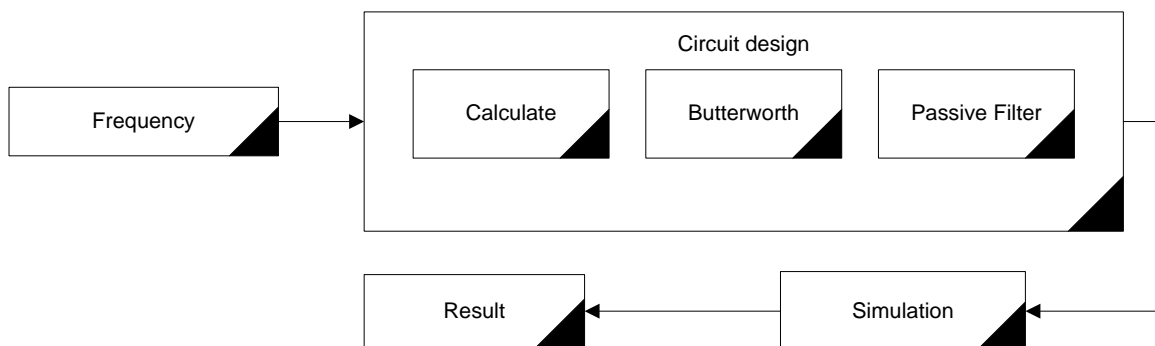

**Figure 1.** Circuit design method.

Bandwidth (BW) = 40 MHz

Calculate

$$f_0 = \sqrt{f_l \times f_h} \quad (4)$$

And

$$C'_1 = C'_3 = C'_4 = Z \times FSF \quad (5)$$

And

$$L'_1 = \frac{Z}{FSF} \quad (6)$$

$$L'_2 = \frac{1}{\omega_0^2 C'_1} \quad (7)$$

$$L'_3 = \frac{1}{\omega_0^2 C'_2} \quad (8)$$

$$L'_4 = \frac{1}{\omega_0^2 C'_3} \quad (9)$$

$$C'_2 = \frac{1}{\omega_0^2 L'_2} \quad (10)$$

When

$f_0$  = Center frequency

$f_l$  = Lower cut – off frequency

$f_h$  = Higher cut – off frequency

$\omega_0$  = Center angular frequency

$R$  = Resistor

$L$  = Inductor

$C$  = Capacitor

$Z$  = Desired impedance level

$FSF$  = Frequency – scaling factor

When

$$\omega_0 = 2\pi f_0 \quad (11)$$

$$FSF = 2\pi(BW_{3dB}) \quad (12)$$

$$Z = R_S = R_L \quad (13)$$

Then, get the circuit as follows **Figure 2**.

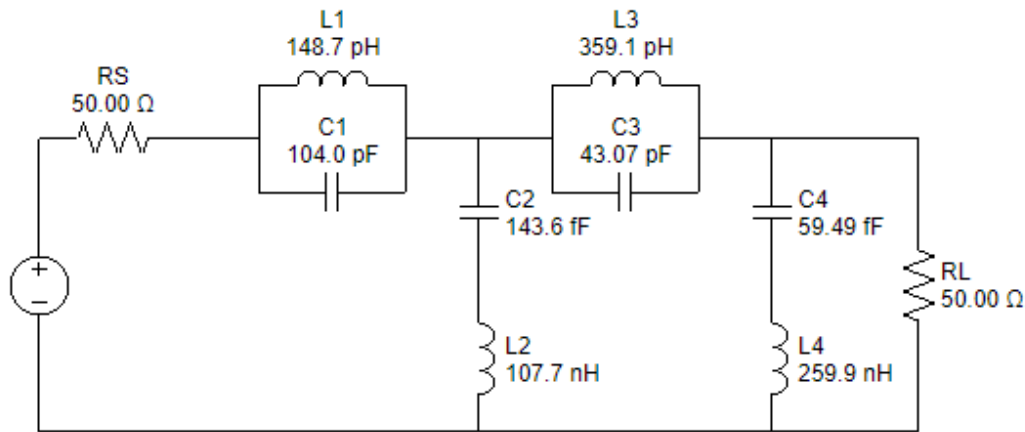

Figure 2. Band reject filter

### 3. RESULTS AND DISCUSSION

The result of band reject filter circuit for design was represented by using Pspice. The output of band-reject filter was at -3dB at 1260 MHz and 1300 MHz. This study discusses about the combination of the LPF and HPF to perform band reject filter. Therefore, there are two combination also in designing band reject filter. The aim of this combination to get know is there have an influence on the performance of band reject filter.

### 4. CONCLUSION

Band reject filter was designed by using the frequency of the GalileoE6 with bandwidth 40 MHz. This filter is used a Butterworth filter which is presented in this study. These filter circuit is composed 4rd order. In addition to, the combination between LPF and HPF forming to a band reject filter is designed. As a result, the filter design on the frequency of Galileo-E6 is successfully used in band reject filter.

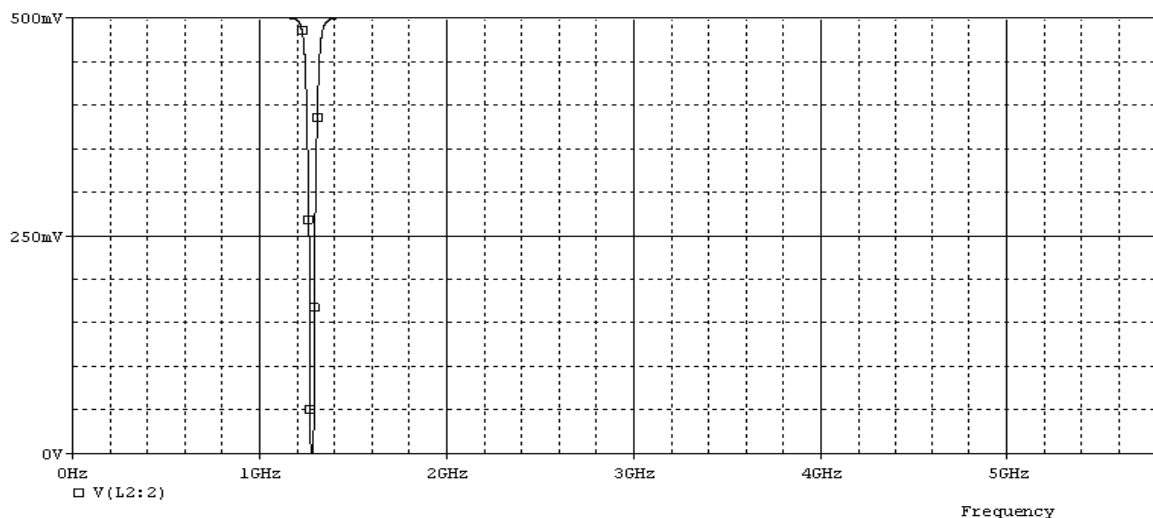
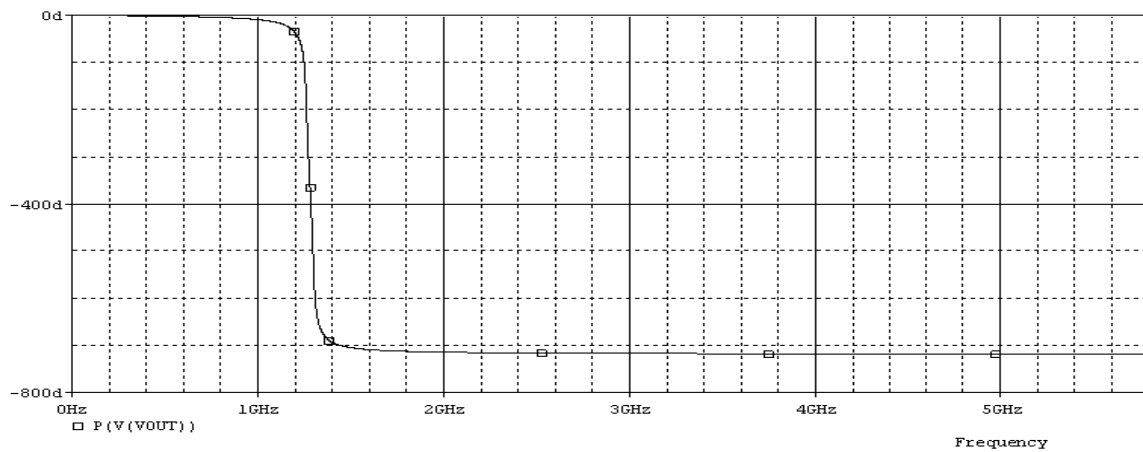

Figure 3. Amplitude-frequency response of band-reject filter



**Figure 4.** Phase response of band-reject filter

## 5. ACKNOWLEDGEMENTS

The researchers would like to thank class members and the professor in the radio frequency and mixed design subject, Department of Engineering Education, School of Industrial Education and Technology, King Mongkut's Institute of Technology Ladkrabang.

## 6. AUTHORS' NOTE

The author states that there is no conflict of interest regarding the publication of this article. The author confirms that the paper is free from plagiarism. There are still many shortcomings and need further research from this article so that the resulting battery is used like a conventional battery.

## 7. REFERENCES

- Aragon-Angel, A., Rovira-Garcia, A., Arcediano-Garrido, E., and Ibáñez-Segura, D. (2021). Galileo Ionospheric correction algorithm integration into the open-source GNSS Laboratory Tool Suite (gLAB). *Remote Sensing*, 13(2), 191.
- Falcone, M., Amarillo-Fernandez, F., Hahn, J., and Favin-Leveque, H. (2002). The galileo system test bed for early prototyping and experimentation of Galileo algorithms. *Proceedings of the 15th International Technical Meeting of the Satellite Division of The Institute of Navigation (ION GPS 2002)*, 2148-2159.
- Hadas, T., Kazmierski, K., and Sośnica, K. (2019). Performance of Galileo-only dual-frequency absolute positioning using the fully serviceable Galileo constellation. *GPS Solutions*, 23(4), 1-12.
- Hegarty, C. J., and Chatre, E. (2008). Evolution of the global navigation satellitesystem (gnss). *Proceedings of the Institute of Electrical and Electronics Engineers*, 96(12), 1902-1917.
- Ortega, L., Poulliat, C., Boucheret, M. L., Aubault-Roudier, M., and Al-Bitar, H. (2020). Optimizing the co-design of message structure and channel coding to reduce the TTD for a Galileo 2nd generation signal. *Navigation, Journal of the Institute of Navigation*, 67(3), 471-492.

- Sagath, D., Vasko, C., Van Burg, E., and Giannopapa, C. (2019). Development of national space governance and policy trends in member states of the European Space Agency. *Acta Astronautica*, 165, 43-53.
- Stansell Jr, T. A. (2020). GNSS interoperability. *Position, Navigation, and Timing Technologies in the 21st Century: Integrated Satellite Navigation, Sensor Systems, and Civil Applications*, 1, 205-214.
- Susi, M., and Borio, D. (2020). Kalman filtering with noncoherent integrations for Galileo E6-B tracking. *NAVIGATION, Journal of the Institute of Navigation*, 67(3), 601-618.
- Das, P., Ortega, L., Vilà-Valls, J., Vincent, F., Chaumette, E., and Davain, L. (2020). Performance limits of GNSS code-based precise positioning: GPS, galileo and meta-signals. *Sensors*, 20(8), 2196.