



Indonesian Journal of Community and Special Needs Education



Journal homepage: <http://ejournal.upi.edu/index.php/IJCSNE/>

Standards for Dimensions of Space and Environment in Buildings for People with Special Needs (i.e. Wheelchairs, Crutches, Canes for The Visually Impaired)

*Ali Rahmat**

Gifu University, Japan

*Correspondence: E-mail: alirahmat911@gmail.com

ABSTRACTS

The purpose of this study is to describe the concept of basic dimensions of space and environment for persons with disabilities. This research was made by conducting a literature review. The results of the study were taken by taking data from the literature. The data is then processed to be presented in the form of an explanation that can be easily understood. Therefore, it is hoped that the research results can be used as a reference for the construction of buildings and the environment, especially for buildings in hospitals, schools, and public facilities for people with special needs (i.e. wheelchairs, crutches, and canes for the blind).

ARTICLE INFO

Article History:

Received 28 Feb 2021

Revised 16 March 2021

Accepted 18 March 2021

Available online 20 March 2021

Keyword:

*Dimension,
Disability,
Environment,
Space,
Special Needs.*

1. INTRODUCTION

The essence taken in the design of this space is the basic dimensions of 3-dimensional space (length, width, and height) which refers to the size of the adult body, the equipment used by the disabled, and the space required (Ball & North, 2007). The data from each existing space is then adjusted to the function which is then set as the maximum capacity of use. The requirements used for space design are (Lindeberg, 1994; Story, 1998).

- (i) The basic size of the space is determined by considering the function.
- (ii) The basic minimum and maximum sizes used in this guide can be increased or decreased as long as the principles of accessibility can be achieved.
- (iii) The need for space for building users and building visitors building.
- (iv) Circulation.

At this time, a lot of information regarding the standard of space. However, there is no specific data written in the form of a scientific paper that explains in open access. Mainly, if the data is presented to people with special needs.

Space and environmental planning in an accessible building is the construction of facilities that can be used by everyone, without any restrictions. This is one of the efforts to equalize persons with disabilities with normal people so that they can live side by side with each other. The main purpose of planning an accessible building is so that there are no barriers that limit normal people with disabilities in their environmental activities. This is following the principle of equity which requires equal rights for everyone in the community.

Accessibility design itself requires a standard that is used as a reference in facility planning. As a result, the planned concept idea is fully supported by legal legitimacy from the Indonesian Government, most recently the enactment of Law Number 8 of 2016 concerning Persons with Disabilities. Accessible design is a product resulting from the planning of the built environment/as one of the pilots that allows everyone to easily access every facility in it.

Accessibility is the convenience provided for people with disabilities in realizing equal opportunities in all aspects of life and livelihood, as to ease of moving through and using buildings and the environment by paying attention to smoothness and feasibility, which is related to circulation, visual and setting components (Phukubje & Ngoepe, 2017).

With these requirements, the purpose of this study is to describe the concept of basic dimensions of space and environment for persons with disabilities. This research was made by conducting a literature review. The results of the study were taken by taking data from the literature. The data is then processed to be presented in the form of an explanation that can be easily understood. Therefore, the research results are expected to be used as a reference for the construction of buildings and the environment, especially for people with special needs.

Disable means a person who has a body disorder in the means of movement that includes muscles, bones, and joints both in structure and function that can interfere with or become obstacles and obstacles for him to carry out activities properly. An explanation of the disabled or people with special needs is explained in the literature (Watson, 2012).

With the standard size of the basic space and environment, especially if the condition of the building cannot meet the standard size, construction planners can make adjustments to the basic size of the space along with the principles of Universal Design. As a result, users in the building or buildings and visitors can still move easily, safely, comfortably, and independently.

2. METHODS

The method used is to conduct a literature review of some data regarding the standard size of space and the environment.

3. RESULTS AND DISCUSSION

3.1. Standard Room Size for People

Figure 1 shows the standard room for people standing, while Figure 2 is the standard room for people sitting. In summary, when people stand and sit, the space required is 165 cm wide.

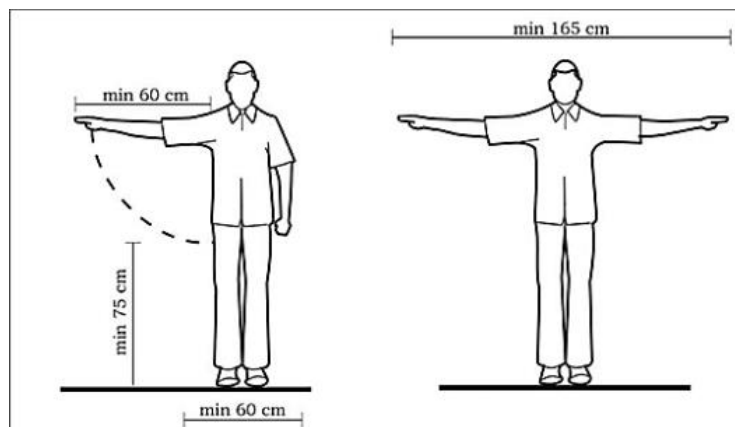

Figure 1. Standard room size for standing people.

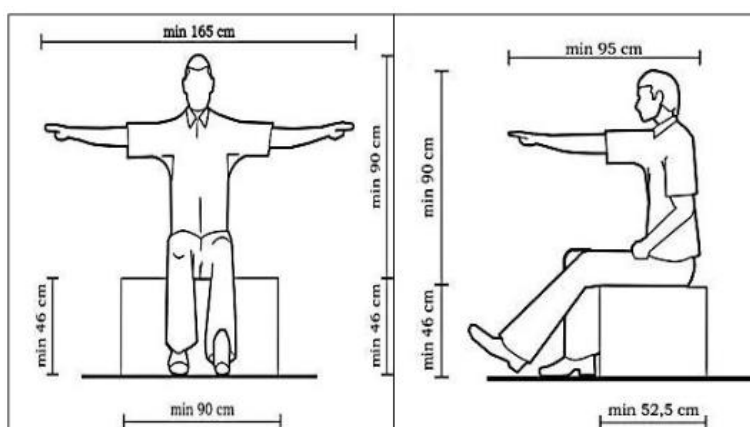

Figure 2. Standard room size for people while sitting.

3.2. Standard Room Size for People with Wheelchair

Figure 3 shows the standard size of a wheelchair. As shown in the picture, the size of the wheelchair when moving requires 132 cm of space.

Figure 4 shows the standard size for a wheelchair when used. To move freely, a minimum of 165 cm of space is required. And if wheelchair users can maneuver, 200 cm of space is required.

Figure 5 shows a standard measure of the reach of people with wheelchairs. All tools and equipment must be stacked 90 cm high. If the object is more than 90 cm, wheelchair users will find it difficult to reach it.

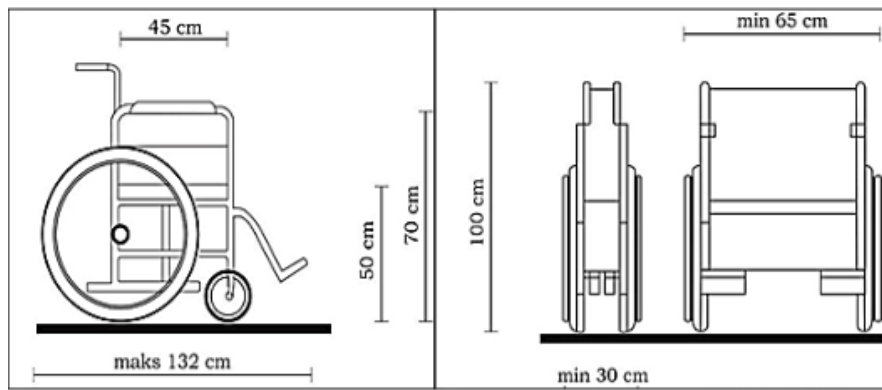

Figure 3. Standard room sizes for wheelchairs.

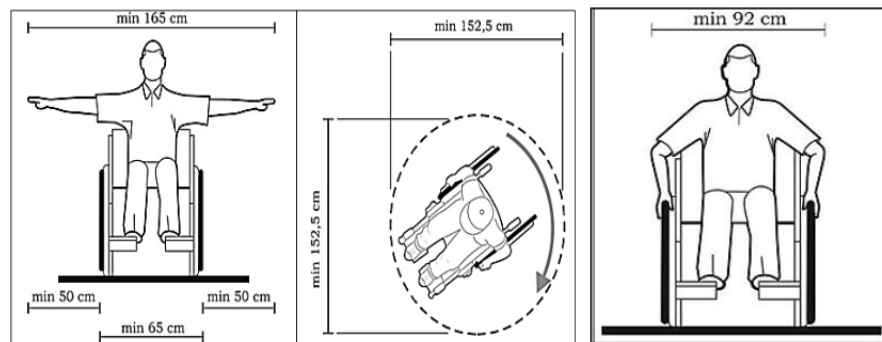

Figure 4. Standard sizes of people with wheelchairs.

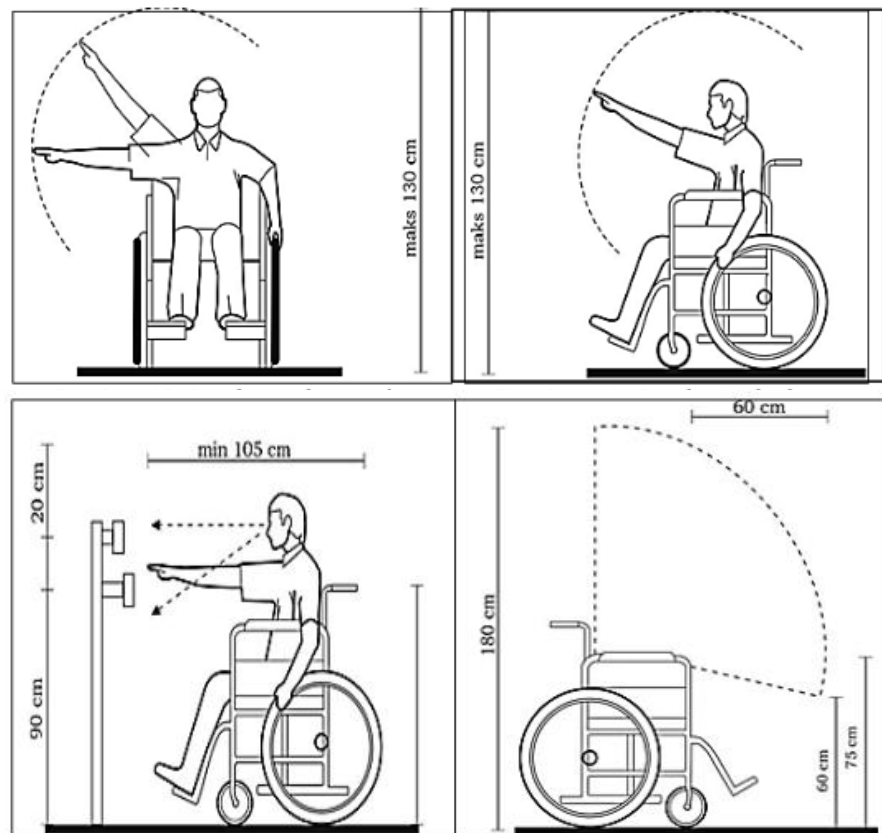

Figure 5. Standard room size for wheelchairs to reach objects.

3.3. Standard Room Size for Blind People with Crutches and Crutches

Figure 6 shows the standard size and reach for a person with crutches. The standard size that should be provided is 120 cm.

Figure 7 shows a standard measure of the reach of a person with a blind cane. The size of the space used is about 90 cm.

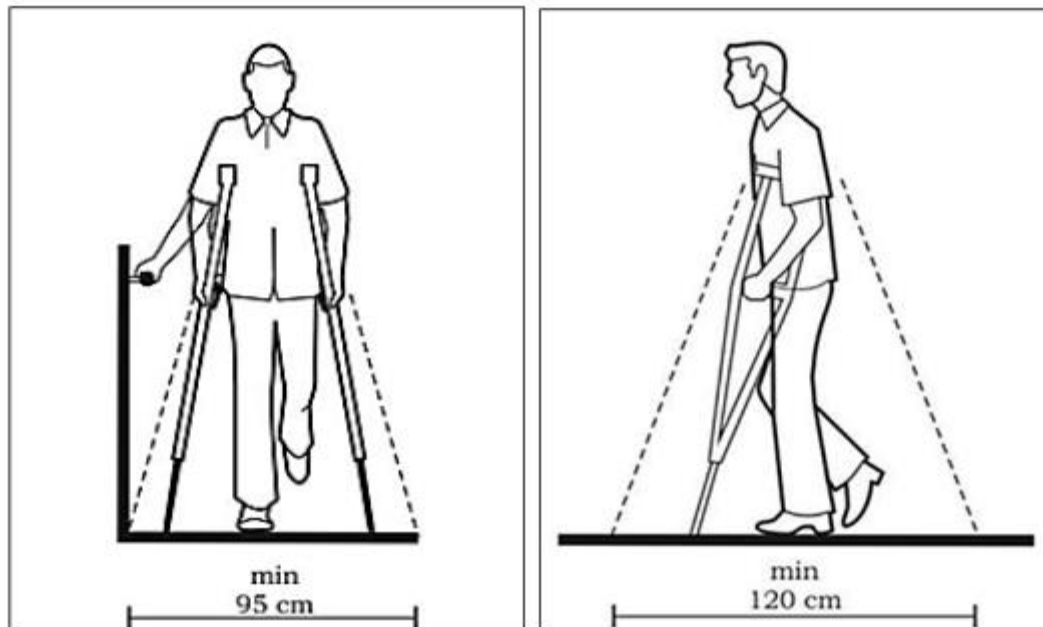

Figure 6. Standard room size and reach of people with crutches.

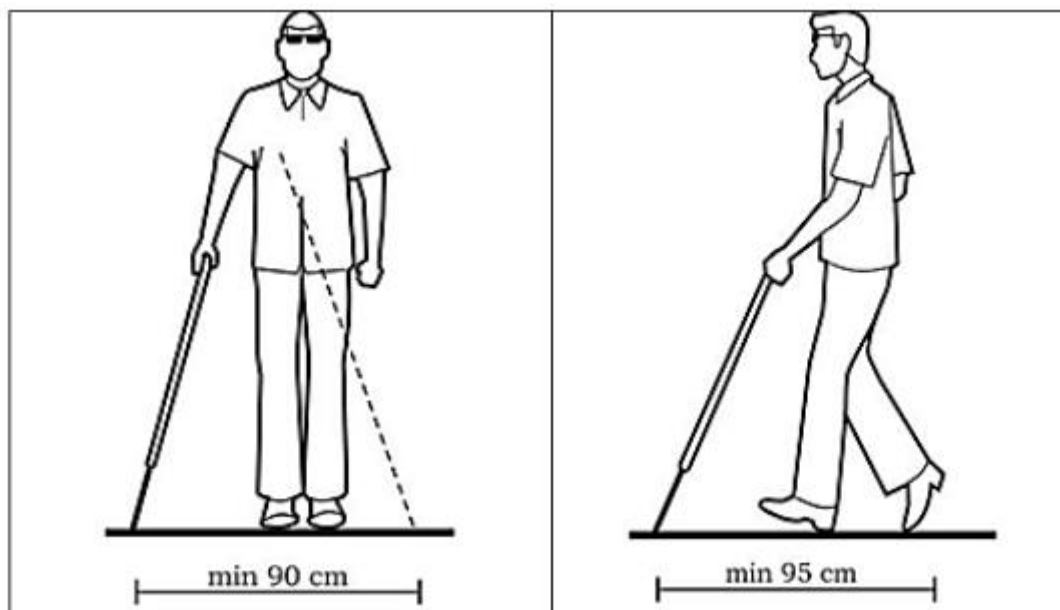

Figure 7. Standard room size and reach of people with blind sticks.

4. CONCLUSION

This paper describes the concept of basic measures of space and environment for persons with disabilities. This research was made by conducting a literature review. The results of the study were taken by taking data from the literature. The data is then processed to be presented in the form of an explanation that can be easily understood. Therefore, it is hoped

that the research results can be used as a reference for the construction of buildings and the environment, especially for buildings in hospitals, schools, and public facilities for people with special needs (i.e. wheelchairs, crutches, and canes for the blind).

5. AUTHORS' NOTE

The authors declare that there is no conflict of interest regarding the publication of this article. Authors confirmed that the paper was free of plagiarism.

7. REFERENCES

Ball, R., and North, C. (2007). Realizing embodied interaction for visual analytics through large displays. *Computers and Graphics*, 31(3), 380-400.

Lindeberg, T. (1994). Scale-space theory: A basic tool for analyzing structures at different scales. *Journal of applied statistics*, 21(1-2), 225-270.

Phukubje, J., and Ngoepe, M. (2017). Convenience and accessibility of library services to students with disabilities at the University of Limpopo in South Africa. *Journal of Librarianship and Information Science*, 49(2), 180-190.

Story, M. F. (1998). Maximizing usability: the principles of universal design. *Assistive technology*, 10(1), 4-12.

Watson, N. (2012). Theorising the lives of disabled children: How can disability theory help? *Children and Society*, 26(3), 192-202.